

ecoHITCH -Designed Specifically For Your **Green Vehicle**

Installation Instructions

Application Fits
2011+ Chevrolet Volt
X7186 & X7187

2" & 1.25" EcoHitch Invisi

200 lbs Tongue Weight/ 2,000 lbs Weight Carrying

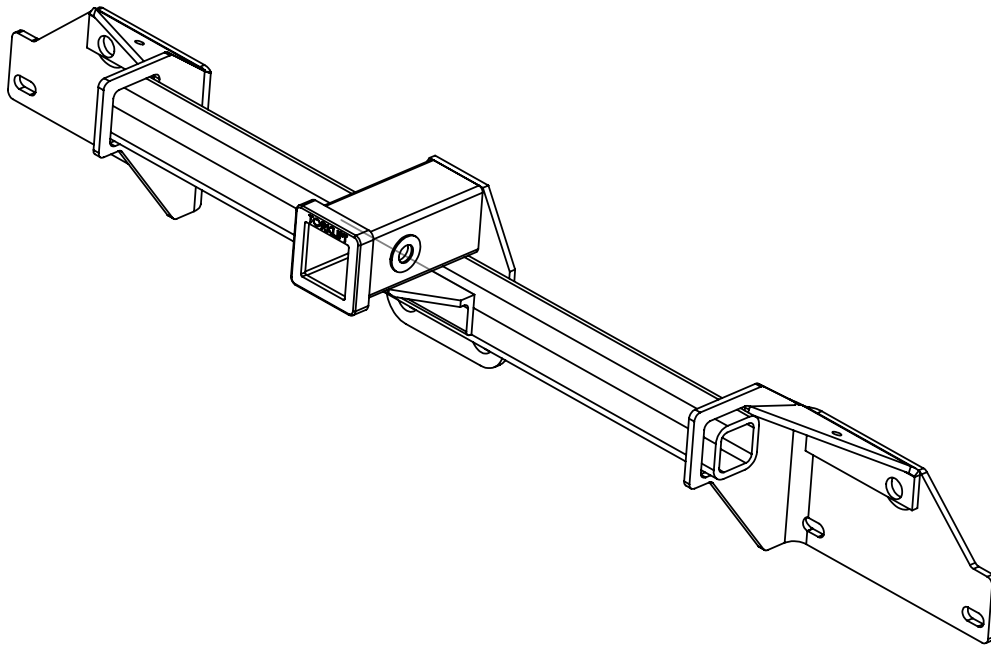

Torklift Central
315 Central Ave N
Kent WA, 98032
253-854-1832
www.torkliftcentral.com
support@tlcentral.com

Stay Connected



torkliftcentral



torkliftcentral



tlcentral



torklift central



torklift central



Hardware Included

QTY Fastener

- 1 License Plate Flip Kit
- 1 Template For License Plate
- 6 Black Zip/Cable Ties

Tools Recommended For Installation

Phillips Screwdriver
Flathead Screwdriver
T20 Torx Bit
3/8 Drive 13MM Deep Socket
3/8 Drive Long Socket Extension
3/8 Drive Ratchet or Impact Gun
3" Hole Saw
4" Hole Saw

READ THESE INSTRUCTIONS THOROUGHLY AND ACCOUNT FOR ALL HARDWARE LISTED BEFORE BEGINNING INSTALLATION!

Take next page and use as template for cutting hole in bumper for trailer hitch.

License Plate Hole- Passengers Side



*Do not use this template on non factory license plate holes.

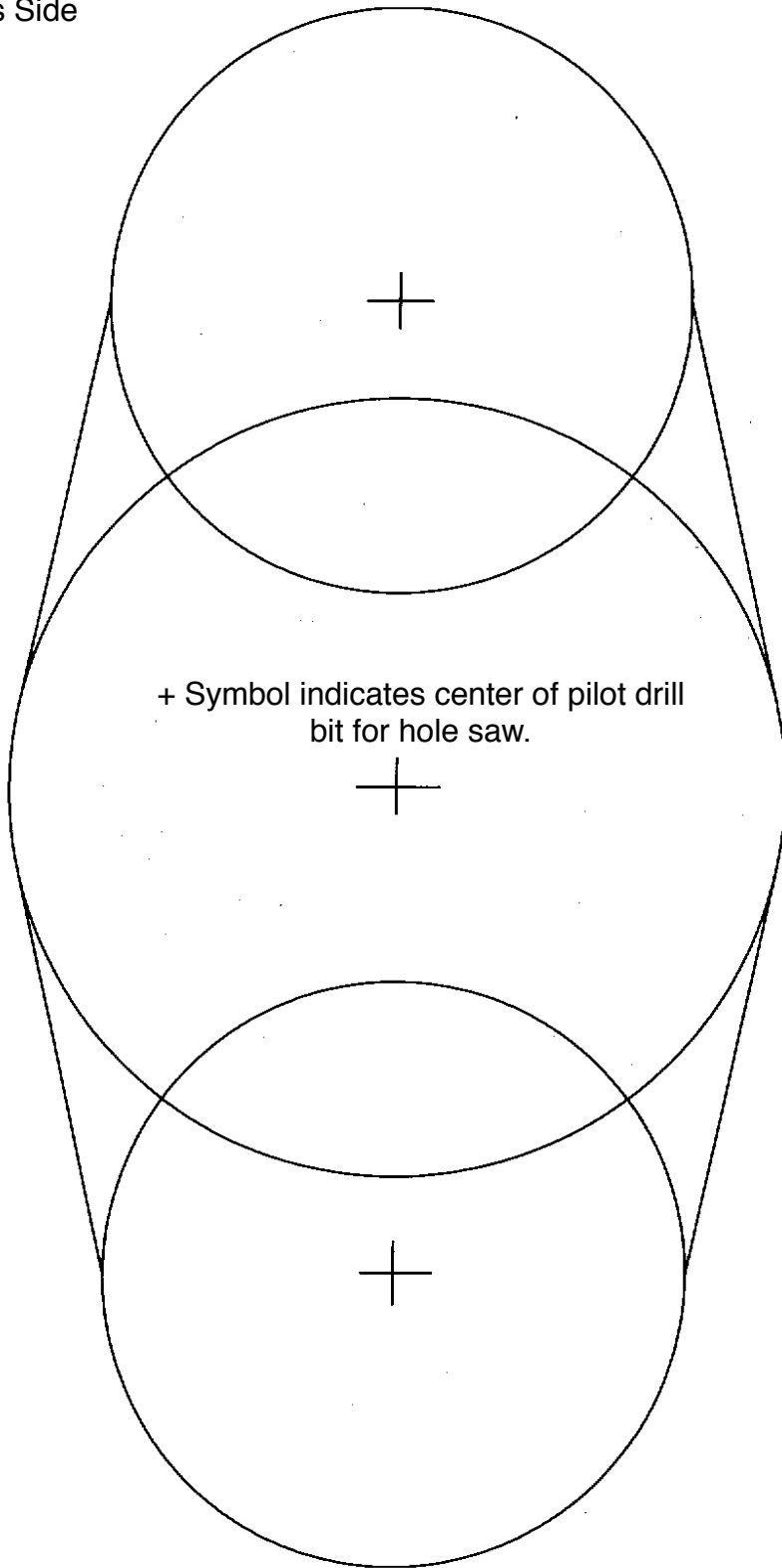

License Plate Hole- Drivers Side



Step 1. Remove fasteners. This will allow you to drop the lower black undercarriage cover. See arrows for fastener location.

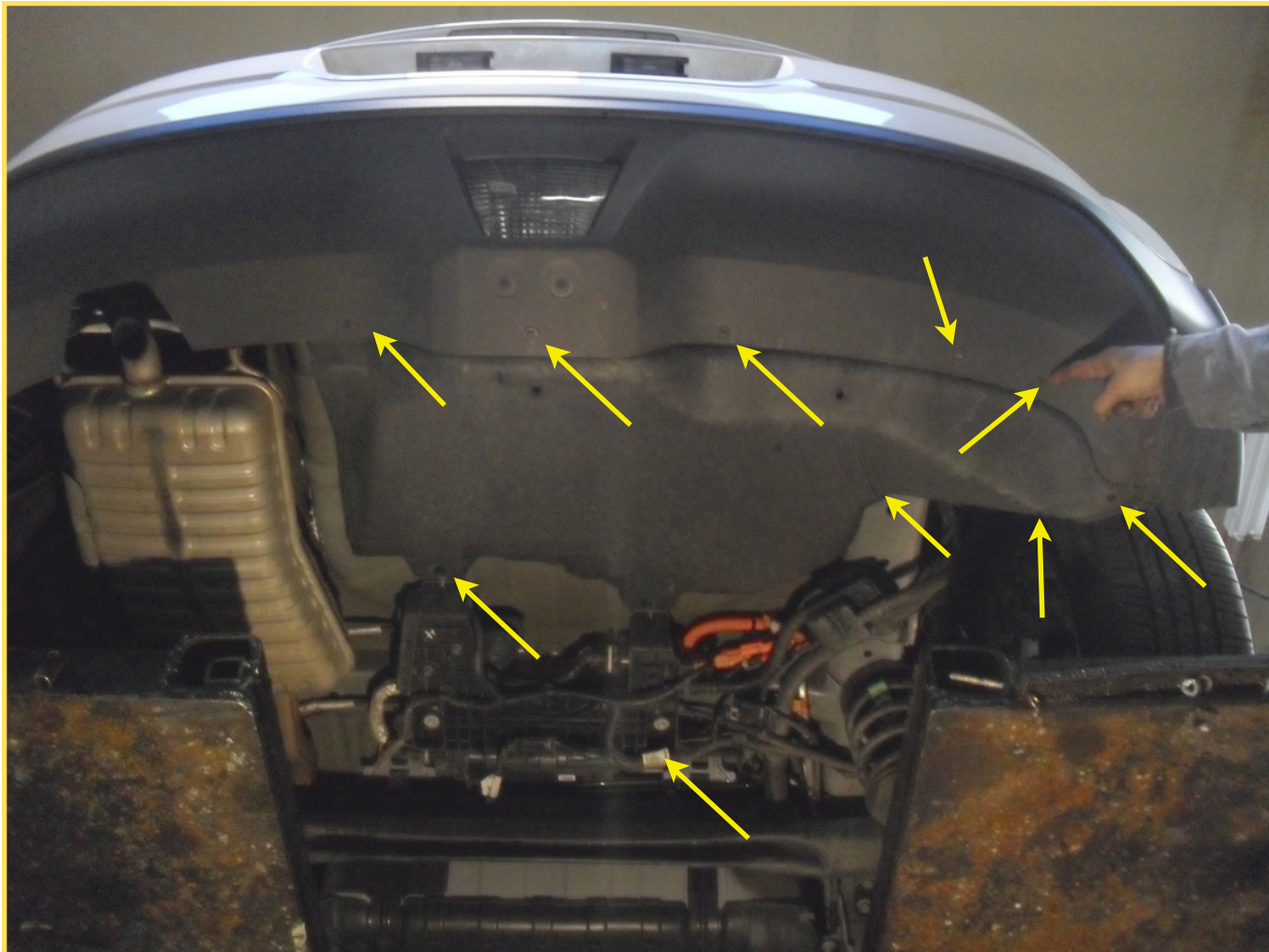

Step 2. Remove license plate from vehicle. Once removed use the template included in the instructions to mark the bumper fascia for holes to be drilled. Be careful to ensure proper alignment of template. Use a high speed drill with both hole saws to ensure smooth cut.



Step 3. Cut zip/cable ties on the lower portion of the bumper fascia and set aside wire harness. This will prepare the wiring harness for when you remove the bumper.



Step 4. Starting with the passenger side rear fender well, remove the torx fasteners from the bumper fascia. There are 4 fasteners total. Use the T20 torx bit to remove these fasteners. Once completed, repeat for drivers side.

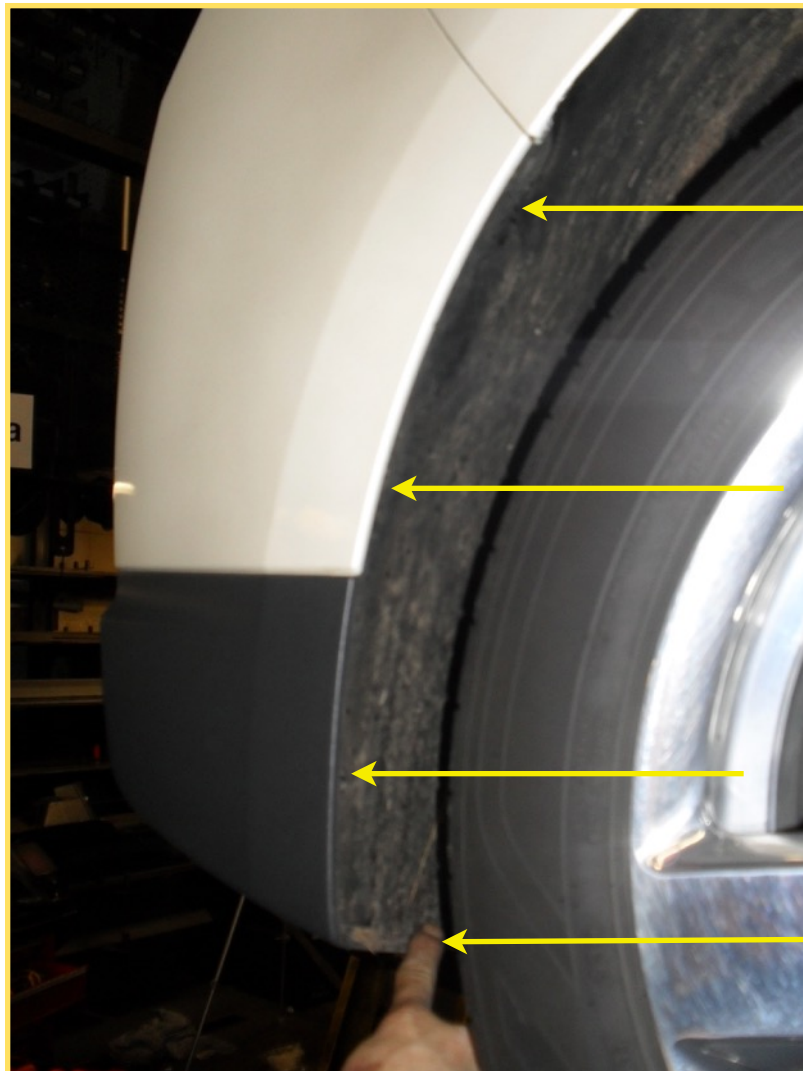

Step 5. Remove the two screws from the bumper fascia as shown.



Screw 1

Screw 2

Step 6.

Rear Bumper Fascia

Procedure

1. Reposition the lower liftgate weatherstrip to access the center fascia guide.
2. Insert a small flat-bladed tool into the fascia center guide and depress the snaps one at a time and pull on the fascia working from one side to the other to remove the fascia from the rear fascia guides.
3. Disconnect the electrical connectors.

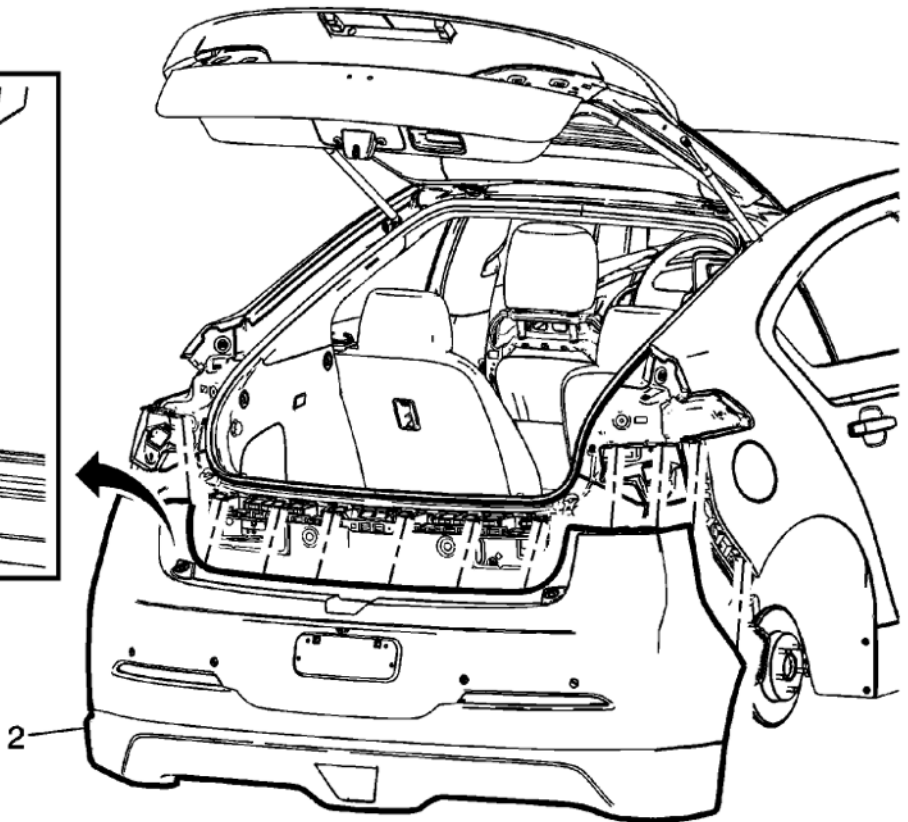
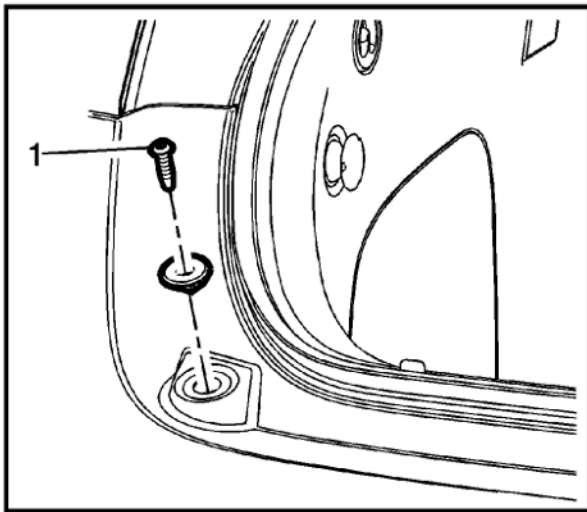

Step 7. Locate the six nuts holding the bumper impact bar to the body.

Use the 3/8 Drive 13MM Deep Socket, 3/8 Drive Long Socket Extension, and 3/8 Drive Ratchet or Impact Gun to remove the six bumper impact bar bolts. Leave nuts close at hand for re-installation.

The trailer hitch will be sandwiched between the bumper impact bar and the body.



Step 8. Position trailer hitch onto six studs. Notice the orientation of the hole pattern. This hitch can only go on one way. Place the bumper impact bar back over the trailer hitch. Hand tighten bumper impact bar nuts to ease the installation of the bumper impact bar. Re-torque bumper impact bar nuts to 38ft lbs.

*****NOTE***** Newer volts have a wire harness stud located near this location. In order to relocate this harness you will need to bend the stud. Using a pair of pliers, gently bend the stud until it is removed from the vehicle.

The hitch includes an additional hole in the support gusset near the stud for wire harness re-attachment. Use the supplied black zip tie to re-locate the harness.

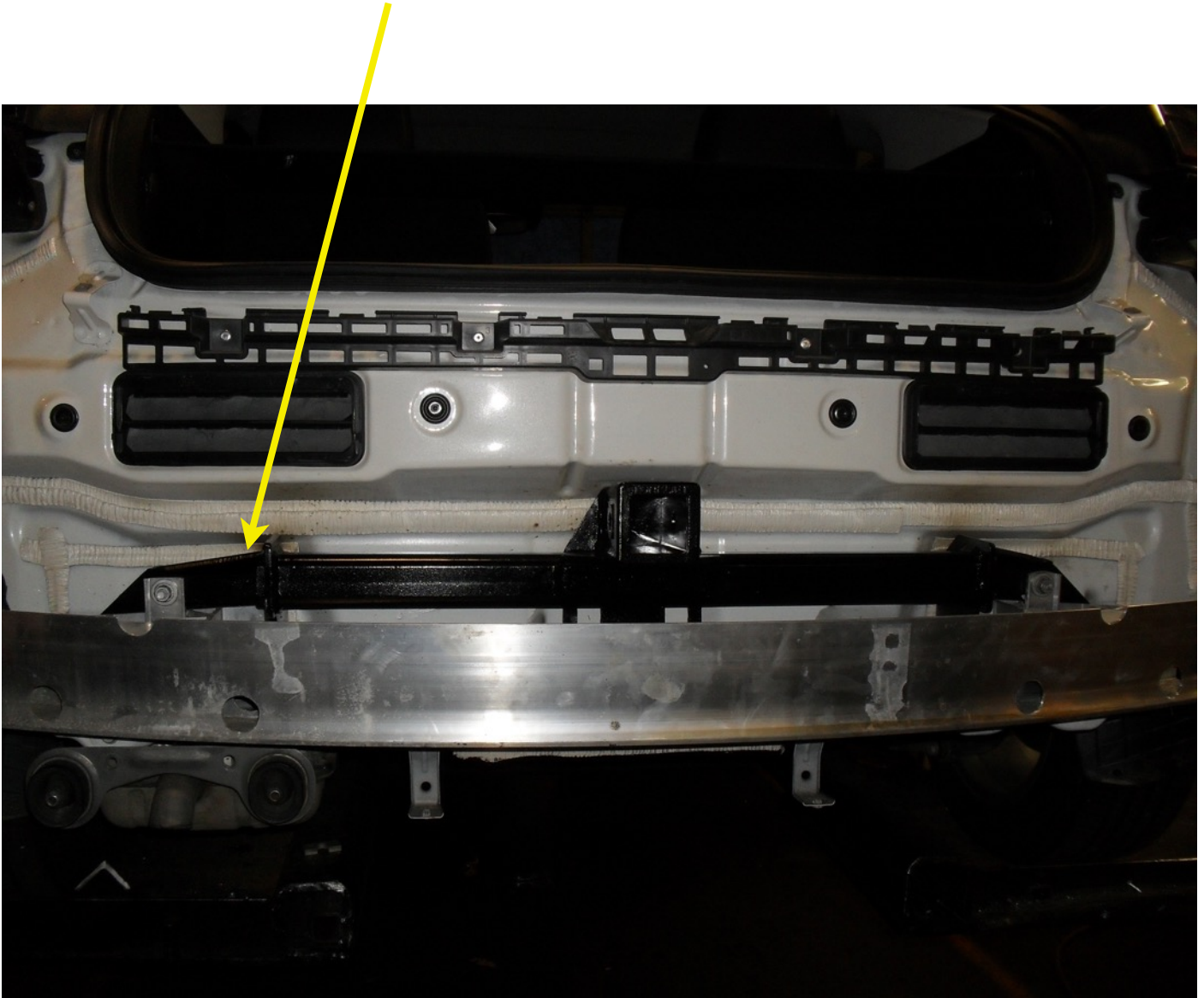

Step 9. Re-install bumper fascia on to vehicle. Push bumper fascia until all plastic clips lock into place on rear fascia guides. Replace all fasteners removed in previous steps.



Step 10. Install flip license plate kit as shown below.



WARRANTY/DISCLAIMER INFORMATION

Torklift Central requires proof of purchase for warranty claim registration, with pictures of any defective product before issuing a replacement. Torklift will not accept claims on any product without proof of purchase, which can be faxed, scanned, emailed or mailed to the information provided below. Torklift Central warrants its hitches, custom hitch receivers and accessories (excluding electrical wire harnesses which carry a warranty from their specified manufacturer) from date of purchase against defects in material and workmanship under normal use and service for the ownership life of the original consumer purchaser. Torklift Central will replace free of charge any part that proves defective in material or workmanship when presented to Torklift Central, transportation charges prepaid by purchaser, at the address below. **This warranty is limited to defective parts replacement only. Labor charges and/or damage incurred in installation or replacement, as well as incidental and consequential damages connected therewith are excluded.** This warranty does not include normal wear and tear or the finish and paint. Rusting, cracking or peeling of the finish is also excluded. Some states do not allow the exclusion or limitation of incidental or consequential damages, so the above limitation or exclusion may not apply to you. Any damage to Torklift Central products as a result of misuse, abuse, neglect, accident, improper installation or any use violative of instructions furnished by Torklift Central will void the warranty. This warranty gives you specific legal rights and you may also have rights, which vary from state to state. With warranty service, you may be able to go to a small claims court, a state court or a federal district court.

Although Torklift Central trailer hitches are both tested and rated for towing within the specific capacity label found on each trailer hitch. Torklift Central assumes no liability for vehicle manufacturers warranty due to the use of a Torklift Central trailer hitch being used for towing behind any vehicle or using the trailer hitch in a manner that it was not designed for. Although this specific trailer hitch has a load rating, which includes trailer tongue weight, and a trailer weight carrying capacity, Torklift Central is not responsible for the voiding of any warranty on any vehicle due to factory towing limitations. All vehicle warranties are the sole property and responsibility of the owner of the vehicle that the Torklift Central trailer hitch is installed upon. Torklift Central does not endorse towing behind any vehicle if the vehicles manufacturer states that towing is not recommended. Check your vehicle's owner's manual for the proper tow rating of your vehicle.

ADDRESS: 315 Central Ave N. Kent, WA 98032

WARNING Your vehicle may have a lower tow rating than this trailer hitch. If your vehicle's tow rating is less than the rated towing capacity on your Torklift Central trailer hitch, your trailer hitch capacity is limited to your vehicle's factory rated towing capacity.

FOR EXAMPLE: the label on your Torklift Central trailer hitch states it's capacity is rated for 500 pounds tongue weight and 5,000 pounds towing weight. However your vehicle's factory rated towing capacity is limited to only 350 pounds tongue weight and 3,500 pounds towing weight. In this example your maximum towing capacity of your Torklift Central trailer hitch is limited to 350 pounds tongue weight and 3,500 pounds towing weight as stated by your vehicle's maximum factory tow rating.

DANGER Never exceed your vehicle's manufacturer's recommended towing capacity which may be a lower rating than this trailer hitch

Unsure of your tow rating? Download our towing app from the app store to find your vehicles tow rating.
www.torkliftcentral.com/app.php